



# **T-300P SERIES**

**T-3250P 250 kVA**

**T-3300P 300 kVA**

**USER MANUAL**



# CONTENTS

<b>SAFETY .....</b>	<b>2</b>
<b>I. GENERAL DESCRIPTION .....</b>	<b>3</b>
1.1 Introduction .....	3
1.2 Design Concept .....	4
1.2.1 The Operating Modes of UPS .....	5
1.2.2 The Power Configuration of UPS .....	5
1.3 Technical Specifications .....	9
<b>II. FRONT PANEL .....</b>	<b>10</b>
2.1 Introduction .....	10
2.2 Alarms And Status Messages .....	10
2.3 Menu Description .....	13
2.4 MAIN MENU .....	15
2.5 MEASURES MENU ITEMS .....	15
2.6 ALARMS Menu Items .....	15
2.7 INFORMATION Menu Items .....	16
2.8 SETTINGS Menu Items .....	16
2.9 COMMAND Menu Items .....	17
2.10 TIME MENU ITEMS .....	18
2.11 PASSWORD Menu Items .....	18
<b>III. PARALLEL OPERATION .....</b>	<b>19</b>
3.1 Introduction .....	19
3.1.1 Security .....	19
3.1.2 Redundancy .....	19
3.1.3 Power Increment .....	19
3.2 Parallel Operation Modes .....	19
3.2.1 Symetric Parallel Mode .....	19
3.2.2 Redundant Parallel Mode .....	20
3.2.3 Hot Standby Mode .....	21
3.3 Parallel Operation Mode Fault Codes .....	21
3.4 Parallel System Accessories .....	21
<b>IV. OPERATING INSTRUCTIONS .....</b>	<b>23</b>
4.1 Introduction .....	23
4.2 Procedure For Switching The UPS To Power The Load From a Power-Off Condition .....	23
4.3 Procedure For Switching The UPS Into a <u>Maintenance Bypass</u> From Normal Operation .....	23
4.4 Procedure For Switching The UPS ON From a Maintenance By-Pass Power Down Condition .....	24
4.5 Procedure For Switching The UPS ON From Static By-Pass .....	24
4.6 Procedure For Completely Powering Down The UPS .....	24
4.7 When Utility Power Is Interrupted .....	25

<b>V. INSTALLATION PROCEDURE</b> .....	<b>26</b>
5.1 Introduction .....	26
5.2 Unpacking.....	26
5.3 Equipment Positioning.....	26
5.4 Connecting The UPS Power Cables .....	27
5.4.1 Safety Earth.....	28
5.4.2 Cable Connections.....	28
5.4.3 Battery Installation.....	31
5.4.4 The Communication (UPS-Server) .....	33
<b>VI. CUSTOMER SERVICE</b> .....	<b>34</b>
6.1 Maintenance .....	34
6.2 Troubleshooting.....	34
6.3 Storage .....	34
<b>VII. REMOTE MONITORING AND CONTROL</b> .....	<b>35</b>
7.1 Using Serial Port .....	35
7.2 Serial Communication Cable .....	35
7.3 Modem Connection .....	35
7.3.1 Hardware Configuration .....	35
7.3.2 Functioning Principle .....	35
7.3.3 SMART Modem Programming (PC modem).....	35
7.3.4 DUMB Modem Programming .....	35
7.3.5 DUMB Modem –UPS Connection Cable.....	35
7.4 Dry Contact (Interface) Connection.....	37
7.5 Remote Monitoring Panel.....	37
<b>VIII. LIMITED WARRANTY</b> .....	<b>38</b>

---

---

## **SAFETY**

This manual contains important instructions for T-300P series UPS that should be followed during installation and maintenance.

### **IMPORTANT NOTICES**

1. Read instructions carefully before operating the UPS
2. All warnings in the manual should be adhered to.
3. All operating instructions should be followed.
4. The unit should be supplied by a grounded outlet. Do not operate the unit without ground source.
5. Power cord of the UPS should be routed carefully so that they are not to be walked on.
6. Please save this manual.
7. Please save or recycle the packaging materials.

### **WARNING !**

- Do not insert any object into ventilation holes or other openings.
- To reduce the risk of fire or electric shock, install in temperature and humidity controlled indoor area free of conductive contaminants.
- To reduce the risk of fire, replace fuses with the same type and rating when necessary.

### **CAUTION !**

- **Only qualified personnel should install or service UPS/batteries.**
- **Risk of electric shock, do not remove cover. No user serviceable parts inside, refer servicing to qualified service personnel.**
- The output may be energized when the unit is not connected to a mains supply.
- **Risk of electric shock hazardous live parts inside this unit are energized from the battery supply even when the input AC power is connected.**
- Turn OFF the UPS before installing a computer interface signal cable. Reconnect the power cord only after signaling interconnections have been made.

### **CAUTION !**

**Units are designed to operate on the concrete floor.**

### **ABOUT THE BATTERY**

- A battery can present a risk of electric shock or burn from high short circuit currents. The following precaution should be observed when working on batteries :
  - \* Remove watches, rings or other metal objects.
  - \* Use tools with insulated handles.
- The batteries in this UPS are recyclable. Batteries must be disposed of according to local environmental laws. The batteries contain lead and pose a hazard to the environment and human health if not disposed of properly.
- Do not dispose of batteries in a fire. The batteries will explode. Do not open or mutilate the batteries. They contain an electrolyte which is toxic and harmful to the skin and eyes. If electrolyte comes into contact with the skin the affected area should be washed immediately.
- The energy source (the battery) cannot be de-energized by the user.

---

---

## I. GENERAL DESCRIPTION

### 1.1 Introduction

T-300P Uninterruptible Power Supplies, are On-Line UPS's, being manufactured with the state-of-the art PWM and IGBT technology, produce microprocessor controlled pure sine wave output to critical loads. T-300P series UPS's install between the critical load and the mains.

The advantages of using UPS:

- **Power blackout protection:**  
If the mains power fails, the UPS continues to power the critical load from its battery source, leaving the load immune from power disturbances.
- **Increased power quality:**  
The UPS has its own internal voltage and frequency regulator circuits, which ensure that its output is maintained within close tolerances independent of voltage and frequency variations on the mains power lines.
- **Increased noise rejection:**  
By rectifying the input AC power to DC power, and then converting it back to AC, any electrical noise present on the input mains supply line is effectively isolated from the UPS output, therefore the critical load sees only clean power.

#### **WARNING for restricted sales distribution.**

#### **Features :**

- Parallel mode operation (optional) up to 2 UPS. (1 redundant)
- **On-line** technology with pure **sine wave** output.
- PWM and IGBT technology.
- **3 Microprocessors at each UPS**
- **Microprocessor controlled main controller board.**
- **Microprocessor controlled rectifier board.**
- **Microprocessor controlled parallel control board.**
- **Static (STS) and maintenance by-pass.**
- LCD (Liquid Crystal Display) display.
- **Alarm history (Memory for max. 64 alarms.)**
- **High quality maintenance-free lead-acid type batteries.**
- **High nonlinear load capacity, special for computers.**
- Automatic and Manual Battery Test System:  
After all the pre conditions ensured, the battery test is made periodically by itself.
- Interactive battery management system (optional)
- Nonlinear loads driving capability.
- Facility of connection with the PC:  
In case of failure, alarms of the UPS (Battery low, mains control or general) is shown by the dry relay contacts and RS232, to the user. The relay interfaces are specially produced for the server systems (IBM AS400 and Microsoft Windows NT).
- Accessories:
  - **Optional UPS monitoring software ( RUPS<sup>®</sup>, RUPSII<sup>®</sup>, UPSILON<sup>®</sup>) SNMP devices, compatible to any operating system.**
  - Remote Monitoring Panel (RMP) available: You can observe the UPS status and parameters without using a computer at a remote location up to 200 meters away (via RS485 interface). Up to 5 remote monitoring panel connection is possible.
  - UPS Port Sharer up to 24 server is available

## 1.2 Design Concept

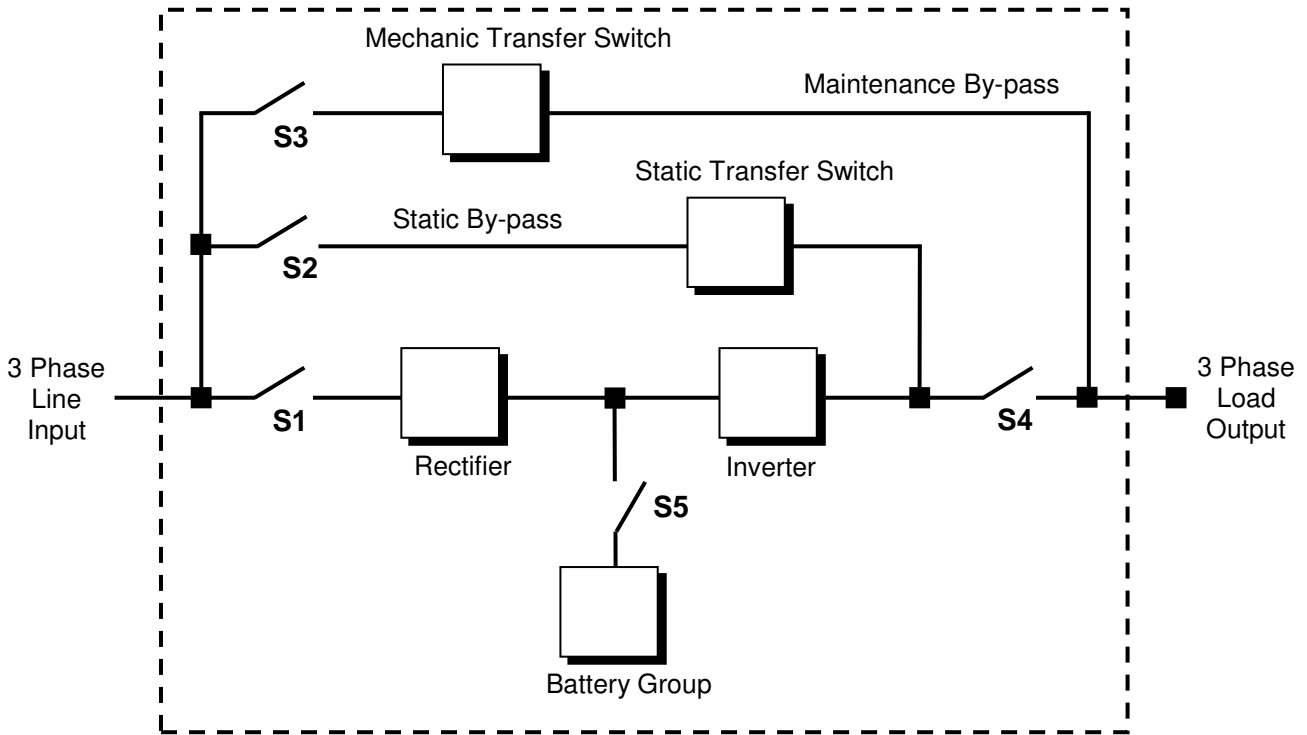

Figure 1-1 Block Diagram

<b>S1</b>	: Inverter input power switch
<b>S2</b>	: Static by-pass input power switch
<b>S3</b>	: Maintenance by-pass power switch
<b>S4</b>	: UPS power out switch
<b>S5</b>	: Battery circuit breaker (optional)

**RECTIFIER:** The first conversion stage (from AC to DC) uses a 3 phase, fully controlled rectifier to convert the incoming mains supply into a regulated DC BUS BAR. The DC BUS BAR produced by the rectifier provides both battery charging power and power to the inverter section.

**BATTERY GROUP:** It keeps as an reserve DC power supply, for the inverter in case of mains failure.

**INVERTER:** It is made by utilizing the latest technology of power transistor (IGBT) and pulse width modulation (PWM). Inverter converts dc bus voltage into (second conversion) an alternative voltage like line voltage. And provides this voltage and frequency being fixed.

**STATIC TRANSFER SWITCH (STATIC BY-PASS):** Two types of bypass circuitry is available for T-300P series UPS

- Full static switch for parallel systems
- Half static switch for normal UPS

The circuit block annotated contains an electronically controlled switching circuit, which enables the critical load to be connected either to inverter output or to a by-pass power source via the “static by-pass line”. Normally at standart models, the load is connected to the inverter via a contactor K1 (controlled by the static switch circuits); but in the event of a UPS overload, or inverter failure, it is automatically transferred to the static by-pass line.

In parallel systems the second static switch is builded, from inverter output, to load.

---

---

**MECHANIC TRANSFER SWITCH (MAINTENANCE BY-PASS):** A second, manually controlled, "maintenance by-pass" supply is also incorporated into the UPS design. Its purpose is to enable the critical load to be powered from the mains (by-pass) supply while the UPS is shut down for maintenance or troubleshooting. The load is unprotected against mains power supply aberrations or failure when it is connected to either the static by-pass or maintenance by-pass supply.

**BATTERY CIRCUIT BREAKER:** There is a fuse loadbreak switch (externally mounted) between the UPS and the batteries. The battery is connected to the DC BUS BAR through a fuse loadbreak switch. This switch has two built-in fuses (one for battery plus, and one for battery minus). This circuit breaker is closed manually. Also **electronic controlled battery circuit breaker** (optional) available. This circuit breaker is closed manually but it contains an under voltage release coil which enables it to be tripped from the UPS control electronics following certain detected faults. It also has a magnetic trip facility for overload protection.

**BATTERY GROUP (CABINET):** The batteries associated with the UPS are generally housed in a purpose-built cabinet located along-side the main UPS equipment. For a long-term efficiency from the batteries, keep them in room temperature (20°C).

### 1.2.1 The Operating Modes of UPS

**A. Normal Operation (If there is a main) :** All relevant power isolators and circuit Breakers Closed (except mechanical bypass circuit breaker), the load is powered by the UPS. Also during the normal operation battery charges. This is made by the UPS's rectifier.

**B. Battery operation:**

During this operation Inverter part of the UPS is converting DC power (from battery group) to AC power, and feeding the load. Critical load works till the batteries are being empty. At the end of discharge UPS gives "A7 BATTERY LOW" alarm. If the batteries are fully discharged UPS gives "A5 BAT.AUT END" message and shutdown. When the mains is restored the UPS returns back to normal operation.

**NOTE:** The battery circuit breaker must be turn to "1" position when the mains is restored. If not in a second main failure the critical load will be without Voltage.

**C. On maintenance by-pass:** UPS shutdown but the load connected to the unprotected mains via the maintenance by-pass supply line.

**D. Parallel operation :** (optional, need special hardware) At least 2 UPS's is installed to system for increasing security and redundancy, they operates together and interactive.

### 1.2.2 The Power Configuration of UPS

The power switch location of the T-300P series UPS's are shown in the figures 1.1-2-3 In the figure 1.2 external (split) by-pass block diagram is given. Optionally the static and mechanic by-pass line can be connect to a different 3 phase AC source ( other UPS etc.), and the rectifier input is connected to generator or mains voltage. If there is no other power supply static and mechanic by-pass line input (S2) and the rectifier input connections will be connect to each other. (See figure 1.1)

During the normal operation except the maintenance by-pass switch, all the Switches will be at "1-On" position.



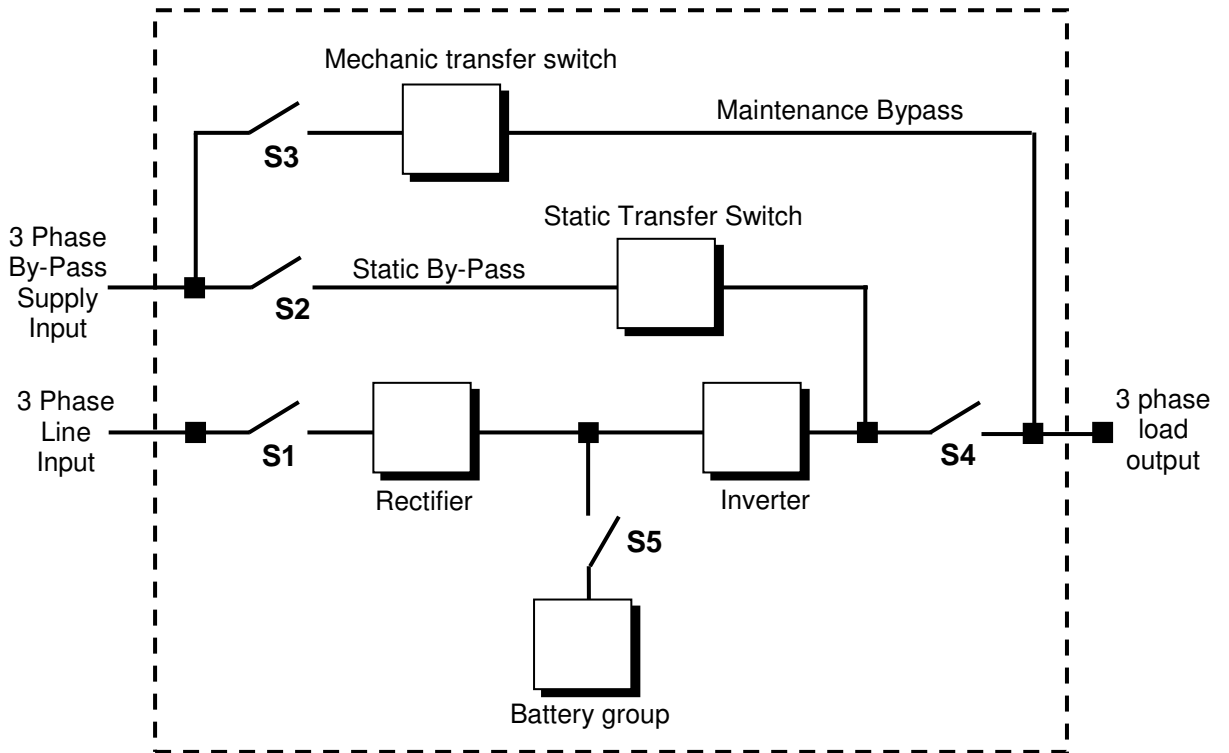

**Figure 1.2** UPS Split (external) By-Pass Block Diagram

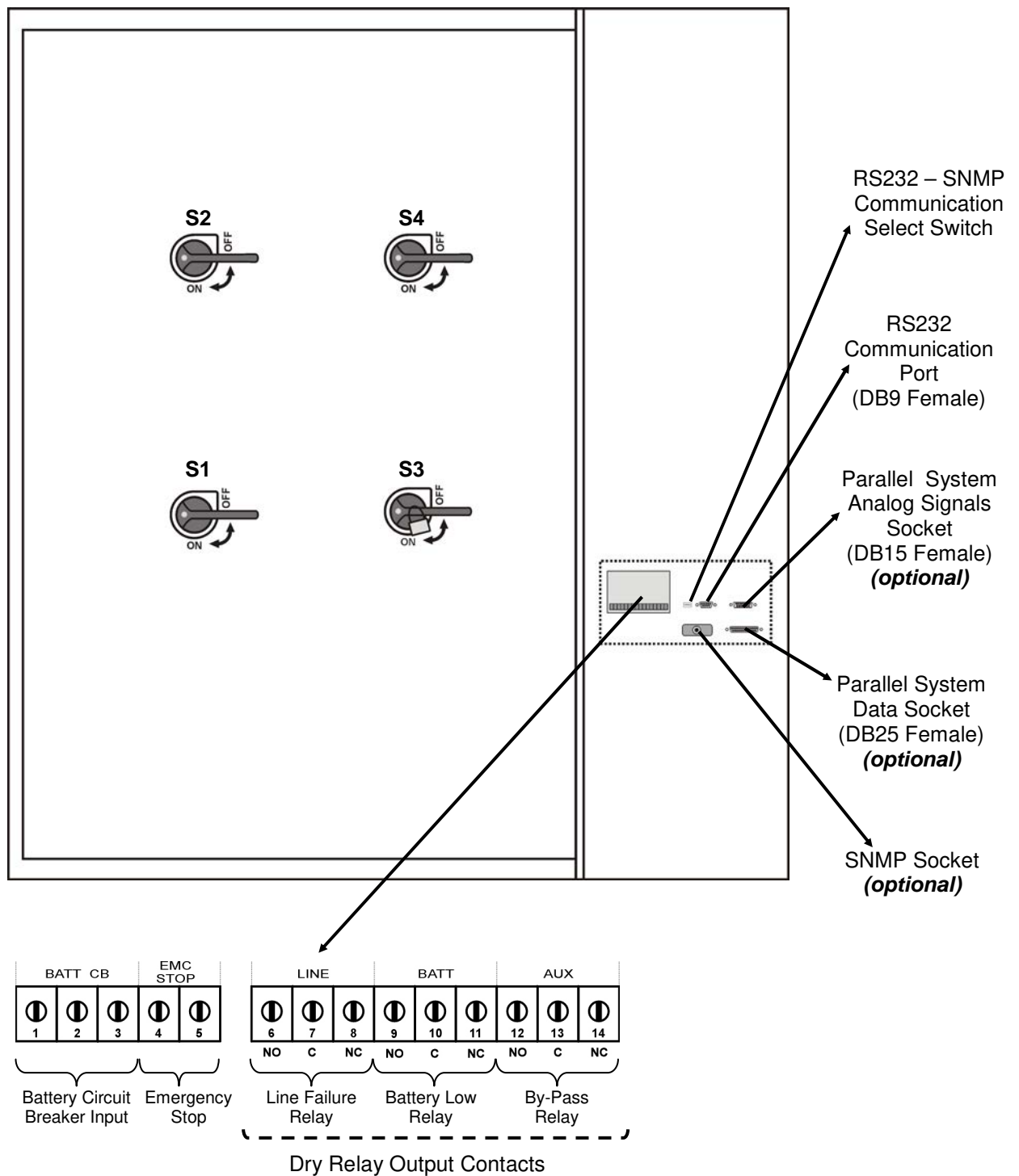

**Figure 1.3** 250-300 kVA Power Switch Locations

### 1.3 Technical Specifications

GENERAL SPECIFICATIONS	250	300
Output kVA	250	300
Output kW	200	240
Output Power factor	0,8	
Parallel Operation	Up to 2 UPS (1 Redundant) (optional)	
Hot Stand-by Operation	Up to 2 UPS (1 Redundant) (optional)	
Battery charging temperature compensation	Optional	
Emergency shutdown	Available	
<b>INPUT</b>		
Number of phase	3 phase	
Input voltage	220/380 Vac or 230/ 400 Vac 3 phase ,N	
Voltage tolerance	+15% , -15%	
By-pass voltage	220/380 Vac or 230/ 400 Vac 3 phase, N	
Input frequency	50 Hz. $\pm$ 5%	
RFI Level	EN 50091	
Split bypass connection	Available	
<b>OUTPUT</b>		
Number of phase	3 phase	
Nominal Output voltage	220/380 Vac or 230/ 400 Vac 3 phase ,N	
Voltage regulation tolerance	$\pm$ 1%	
Nominal Output frequency	50 Hz	
Output frequency tolerance (line synchron)	$\pm$ 2%	
Output frequency tolerance (free running)	$\pm$ 0,2%	
Efficiency 100% Load	90%	
Load Crest Factor	3:1	
Total Harmonic Distortion (THD)	<3%	
Overload	125% load 10 min.150% load 1 min.	
<b>BATTERY</b>		
Number of	32	
Run time	Optional	
Float charge voltage	432 Vdc	
End of charge voltage	320 Vdc	
Boost charge	Available	
Battery Test	1 time in 1 week (manuel test available)	
Charge time	<5 hours at full load	
Battery trip	Available	
<b>INTERFACE</b>		
Communication	RS232(standart) RS485 (optional) Up to 5 remote monitoring panel	
Remote control	Dry contact Line failure,battery low,bypass, EPO ,battery trip in/out	
SNMP capability	Optional SNMP adapter	
Modem connection	Available	
<b>OTHER</b>		
Maximum temperature	0-40°C	
Audible noise	<60 dBA	
Humidity	%10-%90	
Dimensions (HxWxD) (mm)	1880x1565x920	

## II. FRONT PANEL

### 2.1 Introduction

The front panel of UPS, consisting of a 2 lines alphanumeric display ,6 status lamps,plus 5 function keys, allows the complete monitoring of the UPS status. The mimic flow diagram helps to comprehend the operating status of the UPS. By using the function keys operator can moves on menus and change some parameters.

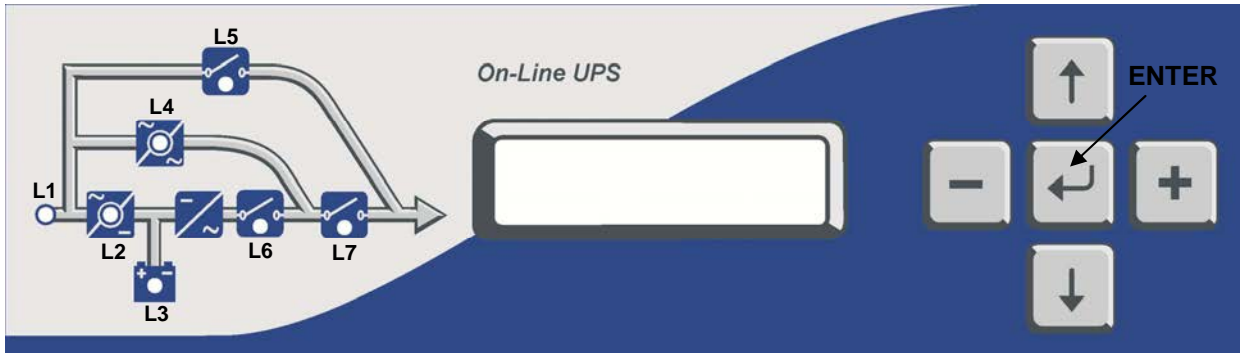

**Figure 2-1** Operator control and indicator panel

- L1** : If lamp is lit mains is okay
- L2** : If lamp is lit the rectifier is operating
- L3** : If lamp is lit UPS is operating on batteries
- L4** : If lamp is lit static bypass is active and load is connected to mains voltage
- L5** : If lamp is lit mechanical bypass switch is on
- L6** : If lamp is lit inverter feeds the load
- L7** : If lamp is lit S4 power output switch "1" on position. (Not exist in 40 kVA)

There are 5 function keys on front panel these are ENTER ,UP ,DOWN ,PLUS and MINUS. UP and DOWN keys help moving on menus , PLUS and MINUS keys select options , ENTER key means the selected option or menu is valid.

**NOTE :** ALL MESSAGES SHOWN IN THIS CHAPTER IS VALID FOR MC VERSION OF UPS CONTROL SOFTWARE.

### 2.2 Alarms And Status Messages

Totally 64 alarm and status messages are used in UPS which helps the user. Messages are coded for easy dialog with service organization,all messages contains numbers A1-A2-A3....An. Messages and events in UPS are recorded to a log file with event time and date

ALARM	DESCRIPTION
<b>A1 BYPASS FAILURE</b> <b>Possible Causes:</b>	Bypass system failure 1) Maybe bypass parts are defective call service
<b>A2 INVERTER FAILURE</b> <b>Possible Causes:</b>	Inverter digital start system is failed Internal failure. Call service.
<b>A3 3 OVERTEMP</b> <b>Possible Causes:</b>	Overload in UPS repeated at 3 times in 30 min. 1) Overload 2) Fan failure or dirty air inlets,outlets 3) Bad UPS settling

ALARM	DESCRIPTION
<b>A4 OUT FAILURE</b>	UPS output voltage is out of tolerance at 3 times in 30 min. Internal failure. Call service.
<b>A5 BATT AUT END</b>	Batteries empty at last of line out. Wait to return of electric.
<b>A6 CHARGER FAULT</b>	Rectifier is not to produce DC bus voltage.
<b>A7 BATTERY LOW</b> <b>Possible Causes:</b>	Batteries are low. 1) UPS wrought long time when line out 2) Charger system failure
<b>A8 OUTPUT HIGH</b> <b>Possible Causes:</b>	Inverter output voltage is over than max. tolerance voltage value. Inverter is stopped. 1) Inverter failure
<b>A9 OVERLOAD</b> <b>Possible Causes:</b>	UPS loaded over than max. %100 load level. Load on the UPS output is over than max. Load capacity. This state is maybe continous or short time. When this alarm is continous to check loads.
<b>A10 LINE FAILURE</b> <b>Possible Causes:</b>	Line failure. 1) Maybe line out 2) There is a problem on the UPS input board. Please Check. 3) UPS input fuses blownd.
<b>A11 HIGH TEMPER</b> <b>Possible Causes:</b>	Over temperature. (inverter or rectifier section) 1) Overload for inverter 2) Over temperature 3) Fan failure or durty air inlets 4) Bad UPS settling. There is not vantilation area.
<b>A12 IGBT FAILURE</b> <b>Possible Causes:</b>	Inverter output system failure. 1) Overload. 2) Short circuit. 3) UPS is out of order. Call service.
<b>A13 OUTPUT LOW</b>	Inverter output voltage is under than min. tolerance voltage value. Inverter is stopped.
<b>A14 BATTERY HIGH</b>	Battery voltage is over than max. tolerance.
<b>A15 FUSE FAILURE</b>	Fuse blownd. (not used at this power range)
<b>A16 BYP INPUT BAD</b>	During transfer to bypass ,Voltage or frequency value of bypass source is incorrect and the UPS turn off the load power. During normal (inverter) operation some times you can see this message. During bypass if the bypass protection option is on and if the bypass source is tolerant out UPS switch off the static bypass for load protection.
<b>A17 BATT CB OPEN</b>	Battery circuit breaker is off ,batteries are not connected to UPS At start up If the mains is okay you can start operation but this message is active At start up During Line failure UPS waits for turn on battery CB and then it starts
<b>A18 BATT.CAPA.LOW</b>	If the battery charge is low this message indicates that charge period is not completed. If mains failure occurs during this message battery operating time is not valid. UPS gives beep sound whitin 15 sec
<b>A19 BATT FAULT</b> <b>Possible Causes:</b>	Battery test aborted. And batteries are not OKAY UPS gives beep sound whitin 15 sec You can clear this message by pressing 3 seconds to ENTER key 1) Rectifier fault 2) Battery cells damaged 3) PURE battery connection
<b>A20 BOOST CHARGE</b>	Boost charge is active for 10 hours. At the end of this time UPS stops the boost charge. UPS gives beep sound whitin 15 sec
<b>A21 ROTATE PHASE</b>	Phase sequence is changed on the UPS input. Please change.
<b>A23 MODE FAILURE</b>	In parallel system, the operation mode of 1 UPS is differenf from the other
<b>A24 P.FAILURE 17</b>	Parallel controller board failure
<b>A25 P.FAILURE 18</b>	Parallel controller board failure
<b>A26 P.FAILURE 19</b>	Parallel controller board failure
<b>A27 P.FAILURE 20</b>	Parallel controller board failure

ALARM	DESCRIPTION
<b>A28 P.FAILURE 21</b>	Parallel controller board failure
<b>A29 P.TEST MODE</b>	Paralel controller is in test mode
<b>A30 P FAILURE 23</b>	Parallel controller board failure
<b>A31 DUBL UPS NR.</b> <b>Possible Causes:</b>	Same UPS number is used in parallel system. 1) Change from settings menu
<b>A39 PSP FAILURE</b>	Power supply is not functioning possibly because either of a wrong phase sequence or rectifier fault.
<b>A40 CANT FIND PR</b>	One of parallel modes is selected but there is no parallel control board on UPS Change mode from settings menu
<b>A41 P.BAL.FAILURE</b>	In parallel operation current sharing is not okay
<b>A42 BATTERY TEST</b>	Performing battery test
<b>A43 P.SYNC.FAIL</b>	In parallel system SLAVE UPS is not synchronized to MASTER UPS
<b>A44 BT.OPERATION</b> <b>Possible Causes:</b>	UPS is operating from batteries 1) Central system is black-out 2) Distribution problems upfront of the UPS
<b>A45 MAINS OK</b>	After mains failure, mains voltage restored again. This message appears on screen for 15 seconds after mains restored.
<b>A46 BOOST CH.END</b>	Boost charge mode is finished, normal charge is valid.
<b>A47 CANNOT START</b>	Analog start system in UPS is failed.

#### Status messages:

This message group simply shows the UPS STATUS at the upper line of LCD PANEL.

<b>RECTIFIER START !</b>	: UPS started the rectifier
<b>INVERTER START !</b>	: UPS started the inverter
<b>MAINT SWITCH ON !</b>	: Maintenance bypass switch is on
<b>MANUEL BYPASS !</b>	: Load is transferred to mains manually
<b>STATUS ALARM !</b>	: Alarm status
<b>STATUS NORMAL !</b>	: UPS is operating
<b>EMERGENCY STOP !</b>	: External emergency signal is detected.
<b>WAITING SYNC !</b>	: Inverter started waiting for synchronization
<b>STATUS FAULT !</b>	: Fault status
<b>CLOSE BATT.CB !</b>	: UPS is waiting for battery CB close
<b>STATUS WARNING !</b>	: Warning message is valid on LCD panel

#### RECTIFIER START :

At start up the UPS controller board check for input voltage, frequency, battery voltage for starting, if these parameters normal UPS starts.

#### INVERTER START :

If the inverter stops controller board tries to start again, during inverter start this message appears on first line of LCD PANEL.

#### MAINT SWITCH ON:

Maintenance bypass switch is connected from input to the output of UPS directly, controller stops inverter for accidental short circuits between mains voltage and inverter output. If the user turn off maintenance switch inverter starts again.

#### EMERGENCY STOP :

If an external EPO switch is installed to system (connected to interface board) ,to stop all UPS parts (rectifier ,static bypass ,inverter ,etc....) is possible . After pressing EPO switch all parts of the UPS stops ,for restart turn off S1 (inverter input) switch and turn on again.

---

---

**FAULT STATUS :**

In some cases controller checks events but can not find solutions, in this case controller decide to stop system ,for restart user must be turn off S1 (inverter input) switch and turn on again.

**WARNING STATUS :**

Some events recorded to log event file stays on LCD PANEL but UPS continues to work, these messages named as warning messages, user can clear this messages by pressing ENTER key for 3 seconds.

These are:

- A20 Boost charge alert
- A6 Charger fault
- A18 Batt capacity low

**Shutdown Messages :**

T-300P series UPS's can operate interactive with operating system, by using some softwares you can send commands to UPS from operating system .UPS takes this commands and produces some messages these are:

**WAITING SHUTDOWN** : Shutdown command is performed from operating system and UPS is waiting for a certain delay for shutdown.

**UPS SHUTDOWN** : UPS is in shutdown status

**WAITING RESTART** : UPS is shutdown but it is waiting for a certain delay for restart

**PAR.SHUTDOWN** : In parallel system the other UPS send shutdown command and UPS is in shutdown status.

**CANCEL SHUTDOWN** : Shutdown command is canceled.

Only operating system or a PC computer can send this commands.

If the shutdown command is performed during line failure UPS shutdowns and is the mains is okay UPS starts again automaticly.

## 2.3 Menu Description

By using UP and DOWN function keys on front panel you can move on main menu functions ,when main menu appears on LCD panel if you press ENTER key you can go to submenu item.

In submenu you can move by UP and DOWN keys ,if there is option on submenu item ,you can change options by pressing PLUS and MINUS keys. If you press ENTER ket the option is valid.

<b>MEASURES submenu</b>
LD% (output load percentage)
OPV (output voltages)
FREQU (output frequency)
IPV (input voltages)
BYP (bypass source voltages)
BATT (battery voltage and current)
..... etc

SAMPLE menu selection:

If you want to go measures menu use UPS and DOWN keys find MEASURES MENU, press ENTER key ,now you can move on measures menu subitems by UP and DOWN keys.

At the end of sub menus ENTER EXIT is located, during this message if you press ENTER key you can go back main menu.

At ALARMS MENU you can see LOG HISTORY, log events are recorded with event time and date.

**PASSWORD** Menu is located for service purposes. This menu is developed for only adjustment.

## Menu and submenu items

MAIN MENU	SUBMENU	MEANING	
<b>MEASURES MENU</b>	LD%: 050 030 060	Output load	
	OPV: 220 221 219 V	Output voltage	
	FREQU: 50.0 Hz	Output frequency	
	IPV: 240 230 226 V	Input voltages	
	BYP: 225 221 219 V	Bypass source voltages	
	IPI: 031 040 020 A	Input currents	
	BATT: 432 V 06.7A	Battery voltage and charge current	
	TEMP: 24 C	Cabinet inside heat	
	CHARGE LEVEL: 60%	Battery charge level	
	ENTER EXIT	Exit from submenu	
<b>ALARMS MENU</b>	UPS STATUS	Valid alarm	
	000>DATE AND ALARM	Recorded log events	
	ENTER CLEAR LOG	Clearing log records	
	PARR.ERR.NR	Parallel control board error nr.	
	ENTER EXIT	Exit from submenu	
<b>INFORMATION MENU</b>	SYNC :OK COMM :OK	Synchronization and communication	
	POWER: 250000 VA	Output power of the UPS	
	VERSION : MC1XX	Version of UPS	
	FREQUENCY : PLL/XTAL	Frequency generation mode	
	ENTER EXIT	Exit from submenu	
<b>PASSWORD MENU</b>	(password required )	System settings	
	ENTER EXIT	Exit from submenu	
<b>SETTINGS MENU</b>	MODE:	Operation mode selection	
	UPS No :	UPS number selection	
	REMOTE :ENABLE	Remote access on/off	
	RESTART:ON/OFF	Mains restored setting	
	BYP.PROTECT ON	Bypass load protection	
	ENTER EXIT	Exit from submenu	
	ENTER B.TEST>432	Manuel battery test	
<b>COMMAND MENU</b>	ENTER <BYPASS>	Manuel bypass	
	ENTER:MODEM INIT	Modem settings	
	ENTER <BOOST>	Boost charge on/off	
	SIMULATION OFF	Simulation mode selection	
	ENTER EXIT	Exit from submenu	
	<b>TIME MENU</b>	TIME : 23 :15	time
		DATE : 11-10-2006	date
		SET HOURS: 11	Adjust hours
SET MINS : 38		Adjust minutes	
SET DAY : 21		Adjust day	
SET MONTH : 06		Adjust month	
SET YEAR : 2006		Adjust year	
ENTER <UPDATE>	Write new time and date		
ENTER EXIT	Exit from submenu		



## 2.4 MAIN Menu

The main menu items is given at the following table you can move on main menu items by using UP and DOWN keys.

Main Menu item	Function
<b>STATUS MENU</b>	The status message which shows the UPS status
<b>MEASURES MENU</b>	→ Enter "go to Measures submenu"
<b>ALARMS</b>	→ Enter "go to Alarms submenu"
<b>INFORMATION MENU</b>	→ Enter "go to Information submenu"
<b>PASSWORD MENU</b>	→ Enter "go to password submenu"
<b>SETTINGS MENU</b>	→ Enter "go to Settings submenu"
<b>COMMAND MENU</b>	→ Enter "go to Command submenu"
<b>TIME MENU</b>	→ Enter "go to Time and date submenu"
<b>Go to STATUS MENU</b>	

## 2.5 MEASURES Menu Items

At this menu you can see all measured values, use UP and DOWN keys for moving on submenu items.

	Submenu item	Function
1	<b>LD%: 060 074 080</b>	Output load percentage (capacity %)
2	<b>OPV: 220 221 220</b>	Output voltages
3	<b>FREQU: 50.0 Hz</b>	Output frequency
4	<b>IPV: 240 235 220</b>	Input voltages
5	<b>BYP: 230 232 231</b>	Bypass source voltages
6	<b>IPI: 022 010 030</b>	Input currents (amperes)
7	<b>BATT: 430 V 22.1 A</b>	Battery voltage and charge current
8	<b>TEMP: 030 c</b>	Cabinet inside temperature
9	<b>CHARGE LEVEL :%100</b> <b>BATT.CAPACI:068%</b>	Battery charge level Remaining battery capacity when operationing on battery
10	<b>ENTER EXIT</b>	→ Enter (↵) exit from menu
	<b>Goto first submenu item</b>	

## 2.6 ALARMS Menu Items

At this menu you can see recorded log events and valid alarms

	Submenu item	Function
1	<b>UPS STATUS</b>	Valid alarm is on LCD PANEL
2	<b>000&gt;311201 23:15</b>	See recorded log events : At the first line the first 3 numbers shows the event number. 000 numbered event is the last event. Date ddmmyy time:hh:mm At the second line of LCD PANEL you can see al recorded alarms. Use PLUS and MINUS keys for moving on events.
3	<b>ENTER CLEAR LOG</b>	→ Enter (↵) clear log event records After you cleared events you see EMPTY LOG message at lines
4	<b>PARR.ERR.NR : 017</b>	Parallel control board fault number. (use if the parallel board is installed) 0 means that there is no error on parallel board
5	<b>ENTER EXIT</b>	→ Enter (↵) exit from submenu
	<b>Goto first submenu item</b>	

## 2.7 INFORMATION Menu Items

This menu gives some information about UPS.

	Submenu item	Function
1	<b>SYNC :OK COMM :OK</b>	If the UPS is operating synchron to mains SYNC:OK ,if not synchron SYNC:-- If communication is active COMM:OK ,if not active COMM:--
2	<b>POWER: 250000 VA</b>	The maximum power rating of the UPS
3	<b>VERSION : MC1xx</b>	Shows the UPS version
4	<b>FREQUENCY : PLL</b>	Frequency generation mode PLL :phase locked loop is generating the frequency XTAL : XTAL oscillator is generating the frequency SLAVE : in parallel system master is generating the frequency
5	<b>ENTER EXIT</b>	→ Enter (↵) exit from submenu
	<b>Goto first submenu item</b>	

## 2.8 SETTINGS Menu Items

From this menu user can set some important options.

	Submenu item	Function
1	<b>MODE: ONLINE</b>	By using PLUS and MINUS keys you can move on 4 operation mode options <b>ONLINE</b> : stand alone mode <b>PARALLEL</b> : 2 UPS in symmetric parallel operation <b>HOT STANDBY</b> : 1 UPS main the other UPS spare mode <b>REDUNDANT</b> : 2 UPS in redundant parallel mode. → press ENTER for 3 seconds and the selection is valid
2	<b>UPS No : 001</b>	By using PLUS and MINUS keys you can change number 0 to 3. In parallel operation select different number for each UPS. If you select the same number DUBL UPS NUMBER message tells the fault. → press ENTER for 3 seconds and the selection is valid
3	<b>REMOTE :ENABLE</b>	By using PLUS and MINUS keys you can change enable and disable options. <b>enable</b> : remote battery test, shutdown and bypass function is enabled <b>disable</b> : these functions are disabled → press ENTER for 3 seconds and the selection is valid
4	<b>RESTART:ON/OFF</b>	By using PLUS and MINUS keys you can change on and off options. <b>ON</b> : during mains failure at the end of battery discharge UPS shutdowns ,after mains restored UPS starts again. (battery trip out is on every time) <b>OFF</b> : during mains restore UPS don't start again. (battery trip out is off) → press ENTER for 3 seconds and the selection is valid
5	<b>BYP.PROTECT ON</b>	By using PLUS and MINUS keys you can change on and off options. <b>ON</b> : if the bypass source is out of tolerant UPS turn off load power. <b>OFF</b> : UPS turn off load power only during bypass moves. If bypass period is completed UPS continues to feed load.
6	<b>ENTER EXIT</b>	→ Enter (↵) exit from submenu
	<b>Goto first submenu item</b>	

## 2.9 COMMAND Menu Items

You can give immediate commands to ups by using this menu.

	Submenu items	Function
1	<b>SOUND : ON/OFF</b>	Use for turn on/off beep alert sound. If you press ENTER key the option will change ,one press ON ,one press OFF. If the OFF option is used sound alert is turn off but if a new different alarm is valid UPS changes de option to ON state.
2	<b>ENTER B.TEST&gt;432</b>	If you press enter for 3 seconds battery test starts for 15 seconds. If battery test failes <b>A6 BATT FAULT</b> message is on panel and this message stays until you press ENTER key for 3 seconds. Numbers at the right shows the battery voltage. Starting of battery test time is recorded to log event menu if the test is successful you can see only <b>BATTERY TEST</b> message on log records..
3	<b>ENTER &lt;BYPASS&gt;</b>	If you press ENTER key for 3 seconds UPS transfers load to bypass. If the load is on bypass in this submenu you see <b>ENTER&lt;INVERTER&gt;</b> message at this position if you press ENTER key for 3 seconds UPS transfers the load on inverter. In parallel modes this function disables and you see <b>BYP.FUNC.DISABLE</b> message on this submenu item.
4	<b>ENTER:MODEM INIT</b>	If you press ENTER key the connected modem of RS232 port is installed UPS sends AT command set to modem for installation. If the function is completed you must hear a beep sound. At the and of this function modem is ready to answer dial up connection.
5	<b>ENTER &lt;BOOST&gt;</b>	If you press ENTER key for 3 seconds boost charge starts. The given time for boost charge is 10 hours. At the end of this time UPS stops the boost charge. If the boost charge is active this submenu item changes to <b>STOP BOOST&gt; 005H</b> message the 005H shows that boost charge is started before 5 hours. If the number is 10 boost charge stops. If you press ENTER key bosst charge stops immediately. Boost charge starting and boost charge end time is recorded to log event menu. If boost is active UPS beeps in each 15 seconds
6	<b>SIMULATION OFF</b>	The purpose of this submenu to check dry contact connections. Normally to check line failure contact you must turn off mains power. This is not necessary with this utility. 3 options are available. <b>SIMULATION OFF</b> simulaion mode is off <b>SIM:LINE FAILURE</b> if you press ENTER key for 3 seconds line failure lamp on interface board lits <b>SIM:LIN.F+BT.LOW</b> if you press enter key for 3 seconds line failure and battery low lamp on interface board lits <b>SIM:BYPASS</b> if you press ENTER key for 3 seconds bypass (aux) lamp on interface board lits. So you can check the connections
7	<b>ENTER EXIT</b>	→ Enter (↵) exit from submenu
	<b>Goto first submenu item</b>	

---

---

## 2.10 TIME Menu Items

You can see date and time of RTC (real time clock) on UPS. And you can adjust date and time.

	Submenu item	Function
1	<b>TIME : 23 :15</b>	time
2	<b>DATE : 11-10-2006</b>	date
3	<b>SET HOURS: 11</b>	(+) and (-) adjust hours (0-23)
4	<b>SET MINS : 38</b>	(+) and (-) adjust minutes (0-59)
5	<b>SET DAY : 21</b>	(+) and (-) adjust day (1-31)
6	<b>SET MONTH : 06</b>	(+) and (-) adjust month(1-12)
7	<b>SET YEAR : 2006</b>	(+) and (-) adjust year (2000-2099)
8	<b>ENTER &lt;UPDATE&gt;</b>	→ Enter update new date and time
9	<b>ENTER EXIT</b>	→ Enter (↵) exit from submenu
	<b>Goto first submenu item</b>	

## 2.11 PASSWORD Menu Items

Only service personnel can use this menu ,the incorrect use of this menu can cause to damage the UPS.

	Submenu item	Function
1	<b>PASSWORD : XXX</b>	Service password input (-) key 100 , UP key 10, (+) key 1 changes after you write the password on screen press ENTER key ,if the password is wrong there is no action. If the password is okay a beep sounds and you see ADJUST MODE at the second line.
2	<b>ENTER EXIT</b>	→ Enter (↵) exit from submenu
	<b>Goto first submenu item</b>	

---

---

## III. PARALLEL OPERATION

### 3.1 Introduction

Two of T-300P UPS can be used in parallel mode, the purpose of parallel use:

- Increasing security
- Redundancy
- Power increment purpose

#### 3.1.1 Security

At stand alone UPS systems mains voltage is spare energy in case of UPS failure, but some critical loads don't works with mains tolerances. Cause of this a second spare UPS is a better solution.

#### 3.1.2 Redundancy

UPS designs are perfect but they takes all mains risks ,sometimes some failures is possible ,the lifetime of batteries and some parts is limited. In such a case the second UPS installed on system will be work on.

#### 3.1.3 Power Increment

Some load systems always develops and the power need increases, the cheepest solution is to install one more UPS to the system.

### 3.2 Parallel Operation Modes

**NOTE:** Parallel control board and some accessories are not installed to standart T-300P series UPS, but parallel operation is available at this models.

Parallel operation is in 3 modes:

- SYMETRIC PARALLEL operation
- REDUNDANT parallel operation
- HOT STANDBY operation

User can select one of the operation modes according to purpose. If parallel control board is installed to UPS You can select operation mode from SETTINGS MENU, in this chapter you can find parallel operation mode informations.

#### 3.2.3 Symetric Parallel Mode

On UPS panel shortly PARALLEL MODE word is used. This mode is usefull at power increment, mains power is spare energy, in case of UPS failure static bypass sytem of all UPS go to bypass together. And if everything is okay go to inverter together.

Current sharing is active, current is %50-50 shared two UPS. During bypass sharing is active.

The general diagram of parallel connection is shown below :

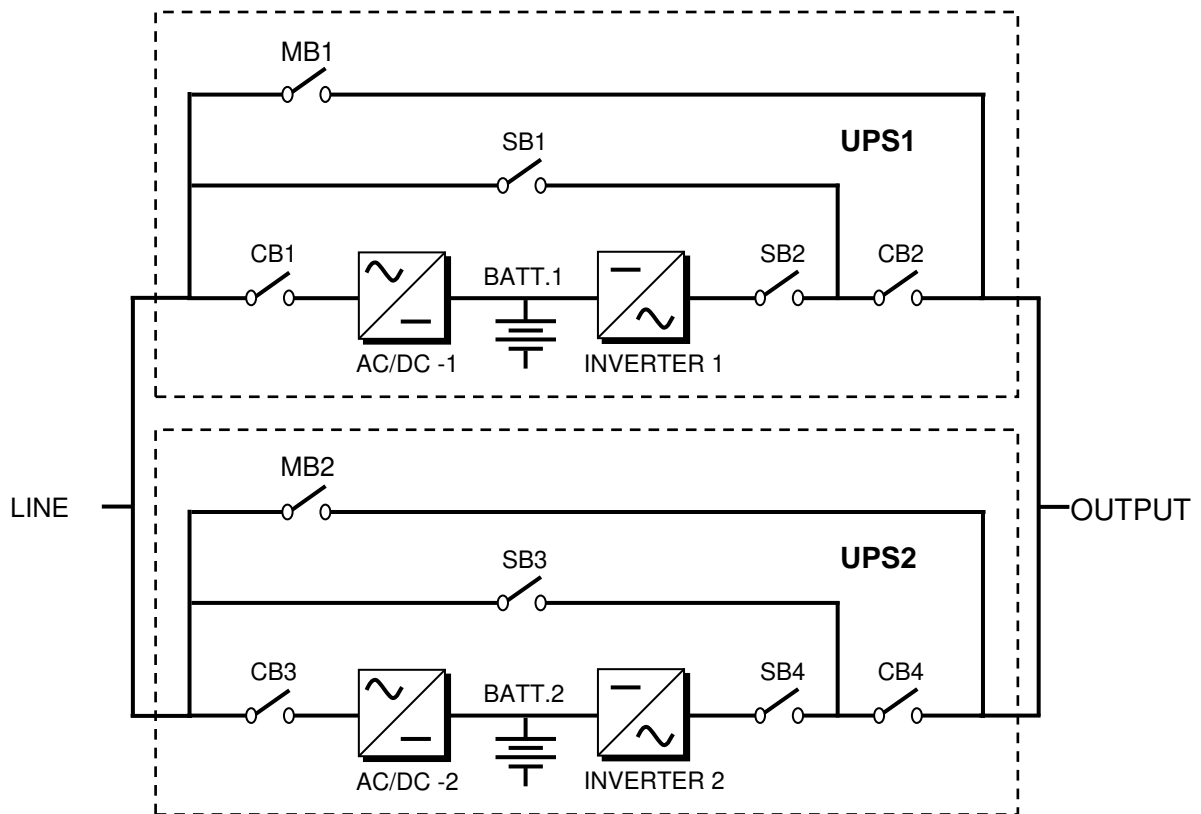

**Figure 3-1** Parallel connected UPS

The inputs of two UPS is connected to mains, outputs of two UPS is connected to each other there is two battery group.

SB1 and SB3 static bypass switches works always together. They turn on/off together. If these static switches is conducted the load is connected to mains directly.

SB2 and SB4 static switches works always together. If these static switches is conducted the load is connected to inverter. In this position current sharing is active.

If a failure occurs at one the UPS, bypass system transfer load to bypass .

At this mode load power is higher than 1 UPS power but lower than the 1UPS+2UPS total power.

### 3.2.4 Redundant Parallel Mode

At this mode if one of the UPS fails the other UPS continues to feed load.

Assume that UPS1 on figure 3-1 is failed, SB1 and SB2 static switches will turn off and the UPS 1 is isolated from load. The SB4 static switch of the UPS 2 will stay in conducted position and it continues to feed the load. If UPS 1 is okay after a delay this UPS will join the system.

If two UPS is in failure SB1 and SB3 static switches will turn on and load is transferred to bypass

This is a 3 level redundancy UPS1+UPS2, UPS2, mains  
Current sharing is active in this mode.

In this mode the power of load must be lower than 1 UPS power.

---

---

### 3.2.3 Hot Standby Mode

If current sharing is active two UPS is operating continuously and lifetime of some parts will be shortened. Hot standby mode is a solution for UPS lifetime.

In this mode UPS 1 feeds the load and the UPS 2 waits spare there is no current it is in standby mode but it is ready to work.

If a failure occurs on UPS 1, static switch system will isolate UPS 1 from load and activate the UPS 2 this is a very fast response, the load doesn't understand the replacement.

Current sharing is not active in this mode.

### 3.3 Parallel Operation Mode Fault Codes

FAULT	DESCRIPTION
<b>A23 MODE FAILURE</b>	SLAVE ups search for the same operating mode with MASTER ups ,if they are different this message locates on LCD panel. Change the operation mode of SLAVE ups from SETTINGS MENU. Don't forget to press ENTER key for 3 seconds Turn off the SLAVE ups and turn on again.
<b>A24 P.FAILURE 17</b>	Parallel Controller Board Failure
<b>A25 P.FAILURE 18</b>	Parallel Controller Board Failure
<b>A26 P.FAILURE 19</b>	Parallel Controller Board Failure
<b>A27 P.FAILURE 20</b>	Parallel Controller Board Failure
<b>A28 P.FAILURE 21</b>	Parallel Controller Board Failure
<b>A29 P.TEST MODE</b>	Parallel control board is in test position
<b>A30 P FAILURE 23</b>	Parallel Controller Board Failure
<b>A31 DUBL UPS NR.</b>	The same UPS number is selected for SLAVE ups ,you must give separate ups number to each ups in parallel system. Goto SETTINGS MENU and change UPS number. Don't forget to press ENTER key for 3 seconds. Turn off the SLAVE ups and turn on again.
<b>A40 CANT FIND PR</b>	Parallel mode is selected but main controller could not find parallel control board. Select ONLINE mode from SETTING MENU. Turn off the ups and turn on again.
<b>A41 P.BAL.FAILURE</b>	Current sharing failed in parallel operation after a delay sharing will try again
<b>A43 P.SYNC.FAIL</b>	In parallel system SLAVE UPS is not synchronized to MASTER UPS After a delay SLAVE ups will try to syncron again.

### 3.4 Parallel System Accessories

At standard T-300P series there is no installed parallel components but they can install. For parallel operation the following parts are necessary:

- Parallel control board
- Current transformers
- Digital connection cable
- Analog connection cable
- Fully static bypass system

During order the customer must give information to factory.

**IMPORTANT NOTE:** Parallel system installation is much more complex from stand alone UPS installation, it needs qualified service personnel.

You have to keep 80 cm distance between two UPS for service purposes. The maximum length of digital and analog cable is 2 meters.

Add %20 tolerant to cables, fuses and circuit breakers in parallel connection.

At figure 3-2 ,the connections of 2 parallel UPS and load switch panel is shown.

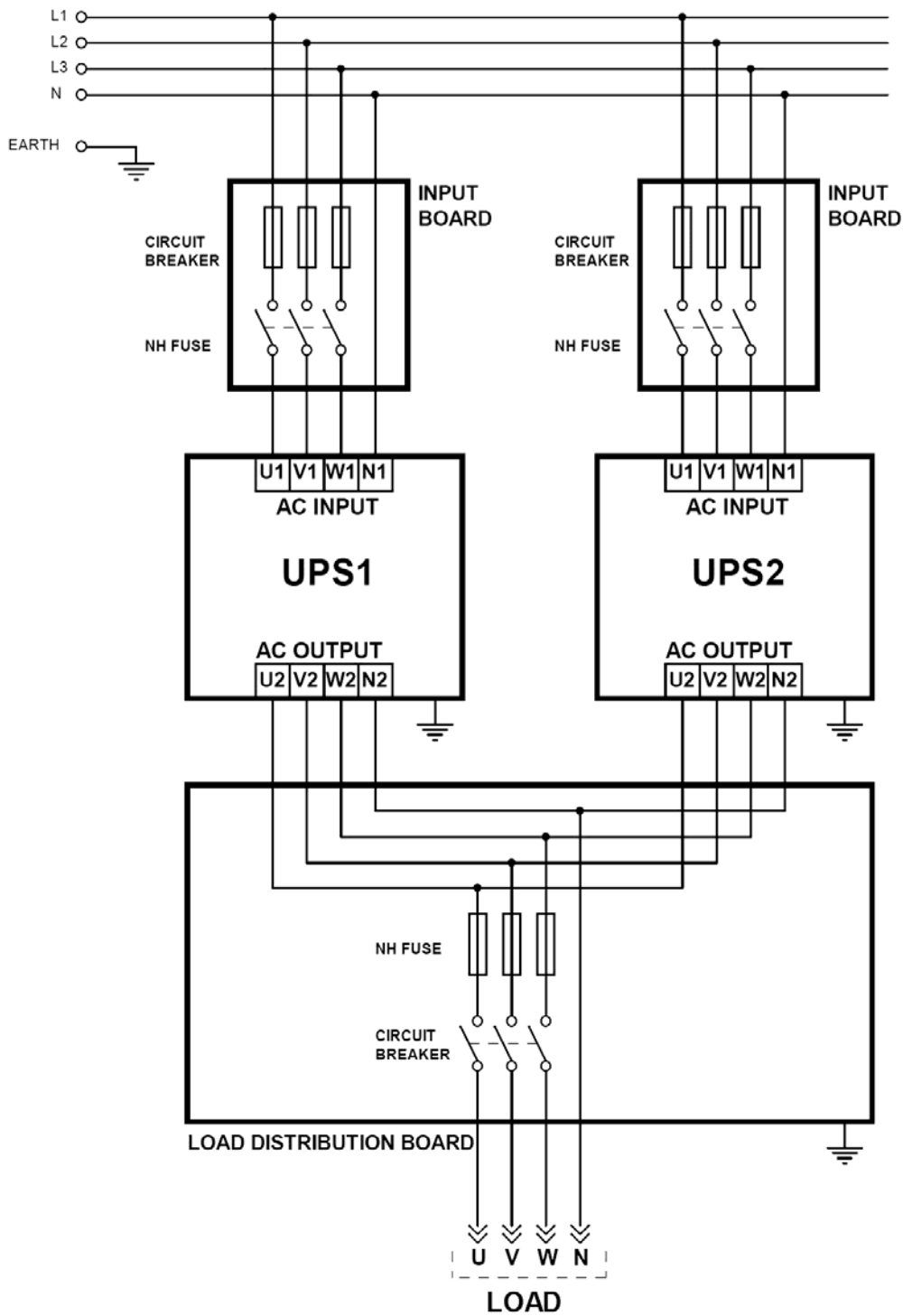

**Figure 3-2** Parallel UPS connection



---

---

## IV. OPERATING INSTRUCTIONS

### 4.1 Introduction

**NOTE1:** All the user controls and indicators mentioned in these procedures are identified in chapter 1. For to make easier to understand some of the procedures there are repetitions.

**NOTE2:** The audible alarm may annunciate at various points in these procedures.

**NOTE3:** In the surroundings of 30 meters radio appliances and radio broadcasting may be disturbed.

The surrounding must be observed against radio interferences. In case the manufacturer has to support suitable modifications.

### 4.2 Procedure For Switching The UPS To Power The Load From a Power-Off Condition

#### TURN ON THE UPS

By applying this procedure UPS returns to normal operation, when it is completely shutdown.

**ATTENTION!!!** The following actions will apply power to the load equipment.

1. Open the UPS doors to gain access to the main power switches.
2. Make sure that S3 switch (maintenance bypass) is in "0" (OFF) position.
3. Turn on the S2 (static by-pass) switch (to "1" position).
4. Turn on the S4 (UPS output) switch (to "1" position).
5. Turn on the S1 (inverter input) switch (to "1" position).

After these procedures, following messages appear on the front panel:

All leds on the front panel are lit for 4 sec. (lamp test)

RECTIFIER START! : Rectifier is working and static bypass continues to supply the load.

INVERTER START! : Inverter is working and static bypass continues to supply the load.

STATUS NORMAL! : The UPS is operating normally, and the inverter is supplying the load.

6. Turn on the battery circuit breaker (to "1" position). By this way it is ensured to connect the battery group to the UPS.
7. When the green led (L6 led) on the inverter is lit, your UPS system is ready to use. You can start up your PC., printer etc.

---

---

### 4.3 Procedure For Switching The UPS Into a Maintenance Bypass From Normal Operation

This procedure should be followed when turning from normal operation to maintenance bypass. This procedure can be used in giving temporary mains voltage to the system during the maintenance of the UPS or in case of failure.

**WARNING !!!** When the UPS is in maintenance bypass or in static bypass position, the loads that are connected to the UPS output are not protected against voltage fluctuations or black outs in the mains supply.

1. Press on the UP or DOWN button until there is "COMMAND MENU" message on the front panel of the UPS. Then press "ENTER" button.
2. Press on the UP or DOWN button until there is "ENTER <BYPASS>" message on the front panel of the UPS. Then press "ENTER" button for 3 seconds. L4 static by-pass led is lit and L6 inverter led is turned off. Now your load is supplied via the Static By-pass switch.
3. Take out the lock from the **S3** (maintenance bypass) switch.
4. Turn on (to "1" position) the **S3** (maintenance bypass) switch.
5. **Then turn off,**
  - S1** (inverter input)
  - S2** (static bypass)
  - S4** (UPS output) switches and the battery circuit breaker, into "0" position.

**WARNING!!!** Inside the UPS the following points will carry hazardous voltages.

- \* By-pass AC input mains terminals
- \* Maintenance by-pass switch
- \* Static by-pass switch
- \* UPS output terminals

Now you're load is completely supplied by the maintenance by-pass and the UPS is in turned off position..

**WARNING!!!** During the maintenance or static by-pass the connected loads at the UPS output can not be protected against the mains failure.

### 4.4 Procedure For Switching The UPS ON From a Maintenance By-Pass Power Down Condition

1. While the S3 switch is in closed position. ("1" position) turn on the S2 (static bypass) and S4 (UPS output) Switches. ("1" position)
2. Turn on the S1 (inverter input) switch. ("1" position)
3. When "MAINT SWITCH ON!" message appears on the front panel, turn off (into "0" position) the S3 (maintenance by-pass) switch. By this way the load will be supplied by the bypass supply via the Static bypass switch.
4. See "STATUS NORMAL!" message on the front panel and the green inverter led is lit.
5. Turn the battery circuit breaker to "1" position. Now the UPS system is in normal operation. You can start-up your PC, printer etc.

---

---

#### 4.5 Procedure For Switching The UPS ON From Static By-Pass

1. Press on the UP or DOWN button until there is “COMMAND MENU” message on the front panel of the UPS. Then press “ENTER” button.
2. Press on the UP or DOWN button when there is “ENTER <INVERTER>” message on the front panel of the UPS. Then press “ENTER” button for 3 seconds. L4 static bypass led is turned off and L6 inverter led is lit. Now your load is supplied by the inverter.
3. See “STATUS NORMAL!” message on the front panel. Now the UPS system is on normal operation. You can start-up your PC, printer etc.

#### 4.6 Procedure For Completely Powering Down The UPS

##### TURN OFF THE UPS

All the power switches, isolators and circuit breakers are turned off (“0” position). There will be no supply voltage on the load.

**WARNING!!!** This procedure will cut the energy to all the equipments, which are connected to UPS output.

- Turn off
  - S1** (inverter input)
  - S2** (static by-pass)
  - S4** (UPS output) switches (to “0” position).
- Open the battery Circuit Breaker (“0” position).

#### 4.7 When Utility Power Is Interrupted

When there is a utility power interrupted, the L6 inverter led continuously lit also L3 battery and on the LCD “**A10 LINE FAILURE**” message appears. And also an audible alarm sounds. Your UPS continues to convert the battery voltage to AC voltage and protect against loss of data and failure. The autonomy can be increased by disconnecting relatively unimportant loads. But do not connect this load again while the autonomy. When the utility power is restored the UPS will return to normal operation and on the front panel of the UPS “**A45 MAINS OK**” message appears.

When there is a “**A7 BATTERY LOW**” message appears and audible alarm sounds shut down your PC. If not all the batteries will be discharge in a few minutes.

After you shut down the critical load (computer system). Apply the completely powering down the UPS. Apply the normal operation procedure to start up the UPS again after a long time later.

**NOTE:** Do not forget to turn on the battery circuit breaker into “1” (ON) position when there is a mains voltage return. If not, in case of a second power cut there will be no voltage for the critical load. If you have a reserve generator, you can use it to feed the UPS’s input and the batteries starts to charge. By using UPS and the generator at the same time ensures to charge the batteries faster.

---

---

## V. INSTALLATION PROCEDURE

### 5.1 Introduction

#### **WARNING!!!**

- Do not apply electrical power to the UPS equipment before the arrival of authorized service personnel.
- The UPS equipment should be installed by a qualified service personnel.
- The connection of the batteries and the maintenance should be done by the qualified service personnel.
- Do not make short-circuit to the batteries poles. Because of the high short-circuit current, it has the danger of electrical shock or burn.
- Eye protection should be worn to prevent injury from accidental electrical arcs. Remove rings, watches and all metal objects. Only use tools with insulated handles. Wear rubber gloves.

This chapter contains location installation information of the UPS and the batteries. All the establishments have their own specialties and needs. So in this part the installation procedure is not being explain step by step. Instead general procedure and the applications are explained for the technical personnel.

### 5.2 Unpacking

The UPS is packed and enclosed in a structural cardboard carton to protect it from damage.

1. Inspect for damage that may have occurred during the shipment If any damage is noted, call the shipper immediately and retain the shipping carton and the UPS.
2. Carefully open the carton and take the UPS out.
3. Retain the carton and packing material for future use.

#### Unit package contents :

- User Manual
- Guarantee Certificate
- Battery cabinet and/or shelf
- Battery Circuit Breaker (Optional)

### 5.3 Equipment Positioning

**ATTENTION: Units are designed to operate on the concrete floor.**

1. The equipment's installation place must be an easy serving place.
2. Install the UPS in a protected area with adequate air flow and free of excessive dust.
3. You must therefore allow for a minimum gap of 250 mm behind the unit to allow adequate air flow (See Figure 5.2)
4. Select a suitable place (temperature is between 0°C and 40°C) and the relative humidity (%90 max)
5. It is recommended to air-conditioned the room (24°C)
6. Temperature is a major factor in determining the battery life and capacity. Battery manufacturers quote figures for an operating temperature of 20°C. On a normal installation the battery temperature is maintained between 15°C and 25°C. Keep batteries away from main heat sources or main air inlets etc.
7. In case of an operating the UPS in a dusty place, clean the air with a suitable air filtration system.
8. Keep out of your equipment from the explosive and flammable items.
9. Avoid direct sunlight, rain, and high humidity.

**WARNING!!!** Check the capacity of the forklift if it is available for lifting.  
DO NOT MOVE THE BATTERY CABINET WHILE THE BATTERIES ARE INSTALLED.

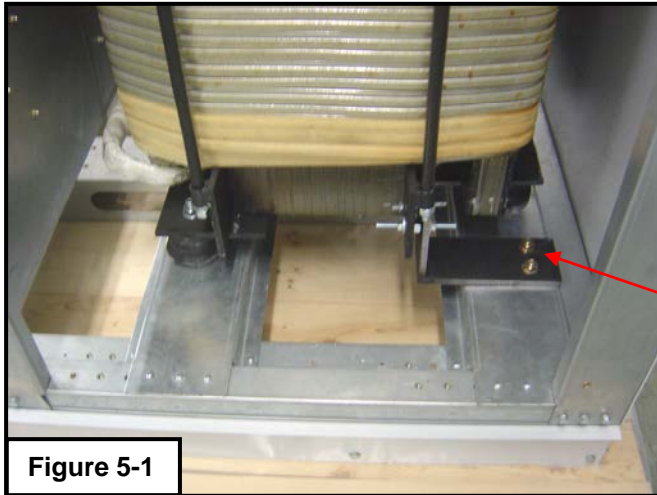

There are two metal pieces mounted for fixing the output transformer during transportation. Please, discard those two pieces during installation of the UPS unit. (Figure 5-1)

Fixing metal piece.  
(The second piece is on the opposite side.)

Figure 5-1

#### 5.4 Connecting The UPS Power Cables

**CAUTION!** Only qualified personnel should install or service UPS / batteries.

The ac input to the UPS should be supplied by a separate line from the ac distribution board.

The input/output cables can be sized to suit the modules rating according to the table below.

The connections of the electric panel should be supplied by grounded outlet. Cables enter the UPS modules via entry panels in the base of cabinet. All control cables should be screened and run in a separate trunking to the power cables.

The input/output cables can be sized to suit the modules' rating according to the table below.

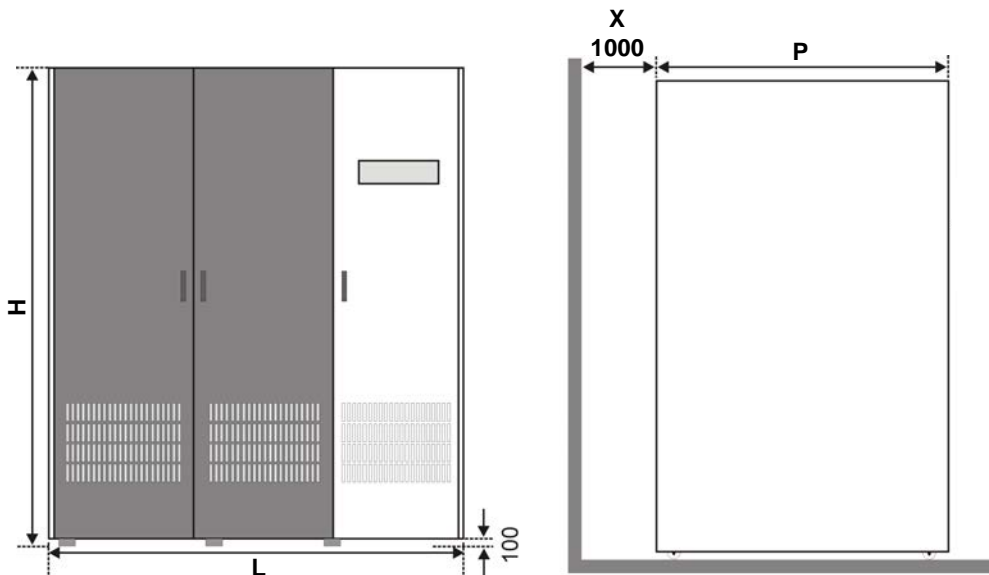

UPS (KVA)	250-300
L	1565
P	920
H	1880
X (min)	1000

**NOTE :**  
All the dimensions are in mm.

Figure 5-2  
Installation Diagram

**WARNING !!! :** This is a product for restricted sales distribution to informed partners. Installation restrictions or additional measures may be needed to prevent disturbances.

**WARNING !!! :** External battery cables must be shielded.

**NOTE :** Output cables must be shorter than 10 meters.

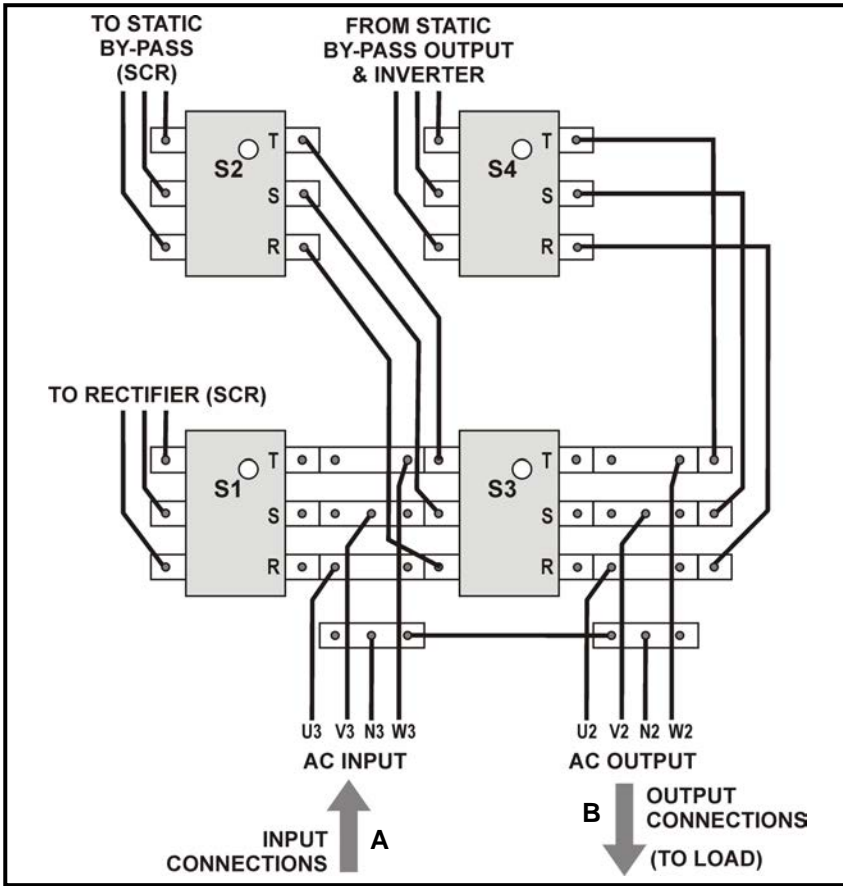

Normal Connections

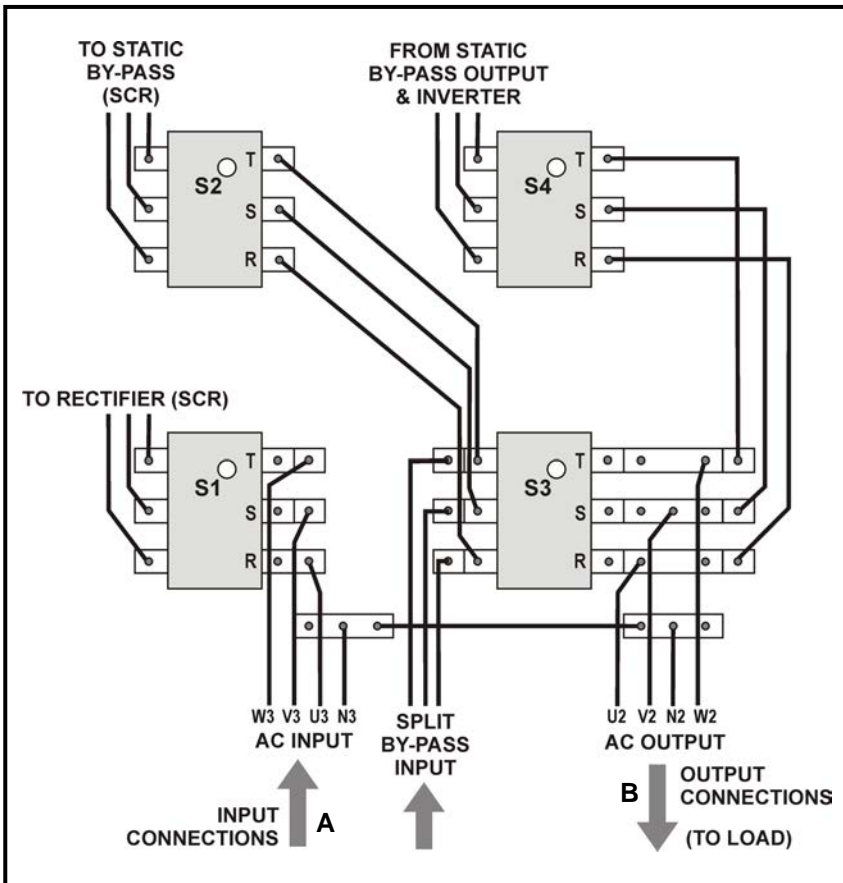

Split By-Pass Connections

Figure 5-3 250-300 kVA UPS Power Connections

UPS RATING (kVA)	NOMINAL CURRENT : Amps / Recommended Cable Size (mm <sup>2</sup> )							BUS BAR CONNECTION STUD SIZE	
	Input Mains With full battery Recharge			Bypass / output At full load			Battery at min. Battery Voltage	Input/Output Cable Terminations	Battery Terminations
	380V	400V	415V	380V	400V	415V			
	A / mm <sup>2</sup>	A / mm <sup>2</sup>	A / mm <sup>2</sup>	A / mm <sup>2</sup>	A / mm <sup>2</sup>	A / mm <sup>2</sup>	A / mm <sup>2</sup>	U-V-W-N	+ & -
250	530A /240	500A /240	480A /240	379A /185	360A /185	347A /185	630A 2x185	M12	M12
300	600A /240	570A /240	550A /240	540A /185	510A /185	490A /185	780A 2x185	M12	M12

**NOTES:** The neutral conductor should be sized for 1,5 times the output/bypass phase current. The Earth conductor should be sized at 2 times the output/bypass conductor (this is dependent on the fault rating, cable lengths, type of protection etc.) These recommendations are for guideline purposes only and are superseded by local regulations and codes of practice.

#### 5.4.1 Safety Earth

The safety earth cable must be connected to the earth BUS BAR and bonded to each cabinets in the system and also the earthing and neutral bonding arrangements must be in accordance with the local laws.

**ATTENTION!!!** Failure to follow adequate earthing procedures can result in electric shock hazard to personnel, or the risk of fire.

#### 5.4.2 Cable Connections

**ATTENTION!!!** All the cable connections of the ups must be done by the authorized service personnel. Once the equipment has been finally positioned and secured, connect the power cables as described in the following procedure:

1. Verify that the UPS's switches are totally at "0" position.
2. Connect the A.C. input supply cables between the mains distribution panel to the B terminals as in Fig. 5-3.

**ATTENTION!!!** ENSURE CORRECT PHASE SEQUENCE

If there is a phase sequence fault, A21/A39 "ROTATE PHASE" message appears on the front panel and the UPS can't work.

3. Connect the UPS output cables from the output terminals to the load distribution panel.
4. Make the connection of the battery groups. Please look at the 5.4 Battery Installation item for it.

**ATTENTION!!!** Remove the battery fuse before making the connection of the battery circuit Breaker during the battery installation. (Turn off into "0" (OFF) position)

5. Connect the copper earth bus, which is under the safety earth and the cables power connection.

**Note:** The earth and the neutral connections must be in accordance to the local Rules.

6. If the REMOTE STOP option is going to be used, you should connect the remote stop button (normally open), to the pins 4 and 5 of the remote stop connector (CN3) on the PCB ITF3.

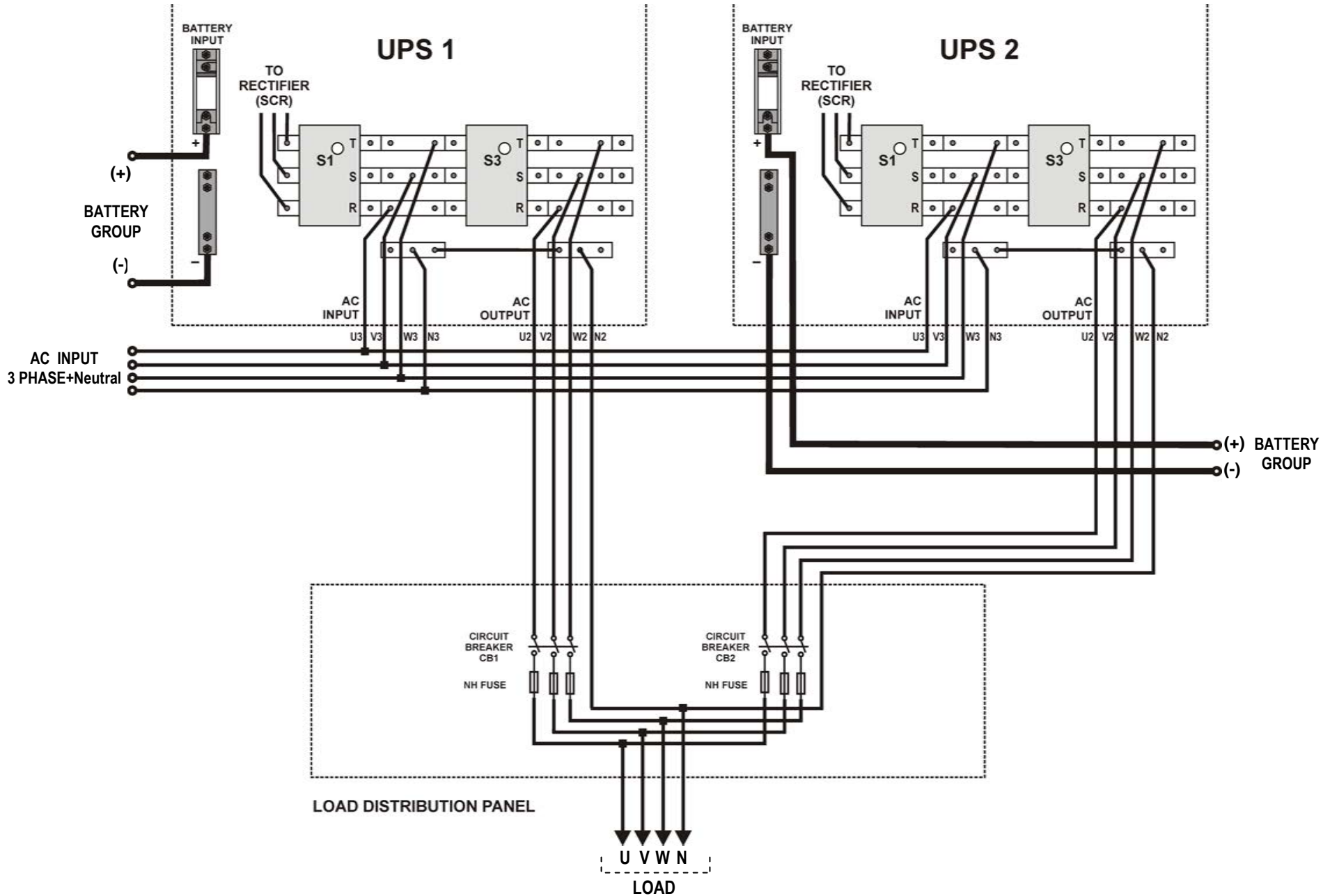

Figure 5-4 POWER CONNECTIONS OF TWO UPS's FOR PARALLEL OPERATION (250kVA)



**5.4.3 Battery Installation**

**ATTENTION!!!** Remove the battery fuse before making the connection of the battery circuit breaker box during the battery installation.

The batteries associated with the UPS equipment are usually contained in a purpose-built battery cabinet, which sits alongside the main UPS equipment. Sealed, maintenance-free batteries are normally used in this type of installations.

Where battery racks are used, they should be sited and assembled in accordance with the battery manufacturer’s recommendations. In general, batteries require a well-ventilated, clean and dry environment at reasonable temperatures to obtain efficient battery operation.

In general a minimum space of 10 mm must be left on all vertical sides of the battery block. A minimum clearance of 20 mm should be allowed between the cell surface and any walls. A clearance of minimum 150 mm should be allowed between the top of the cells and the underside of the shelf above (this is necessary for monitoring and servicing the cells). All metal racks and cabinets must be earthed. All live cell connections must be shrouded.

The batteries are connected to the UPS through a circuit breaker (optional), which is manually closed and electronically tripped via the UPS control circuitry. If the batteries are cabinet-mounted this circuit breaker is fitted within the cabinet; however, if the batteries are rack-mounted or otherwise located remote to the main UPS cabinet then the battery circuit breaker must be mounted as near as possible to the batteries themselves, and the power and control cables connected to the UPS using the most direct route possible.

1. Unpack each battery and check its terminal voltage. If any battery has terminal voltage less than 10,5 V it must be charged before continuing.
2. Please check the battery connecting hardware.
3. Please locate 8 pieces of the batteries to each rack.
4. Start locating the batteries from top to the bottom on the racks.
5. Connect the cable between the battery circuit breaker’s positive port (BAT+) first then battery tray (+) at the left topside as in the figure 5-4
6. Connect the cable between the battery circuit’s negative port (BAT-) first then battery tray (-) at the right bottom side as in the figure 5-4
7. Please pay attention to the connections and the poles’s directions between the racks.
8. Connect the battery circuit breaker’s “UPS(+) ⇒ BATT(+)” and “UPS (-) ⇒ BATT(-)” Ports to the battery group connection terminals at the UPS cabinet.
9. Connect the shielded control cable between the UPS and the battery circuit breaker as in the following.

Battery circuit Breaker box		Inside of the UPS
	1.....1	ITF3 Board
BAC60 Board	2.....2	BATT. CB
CN1	3.....3	CN3

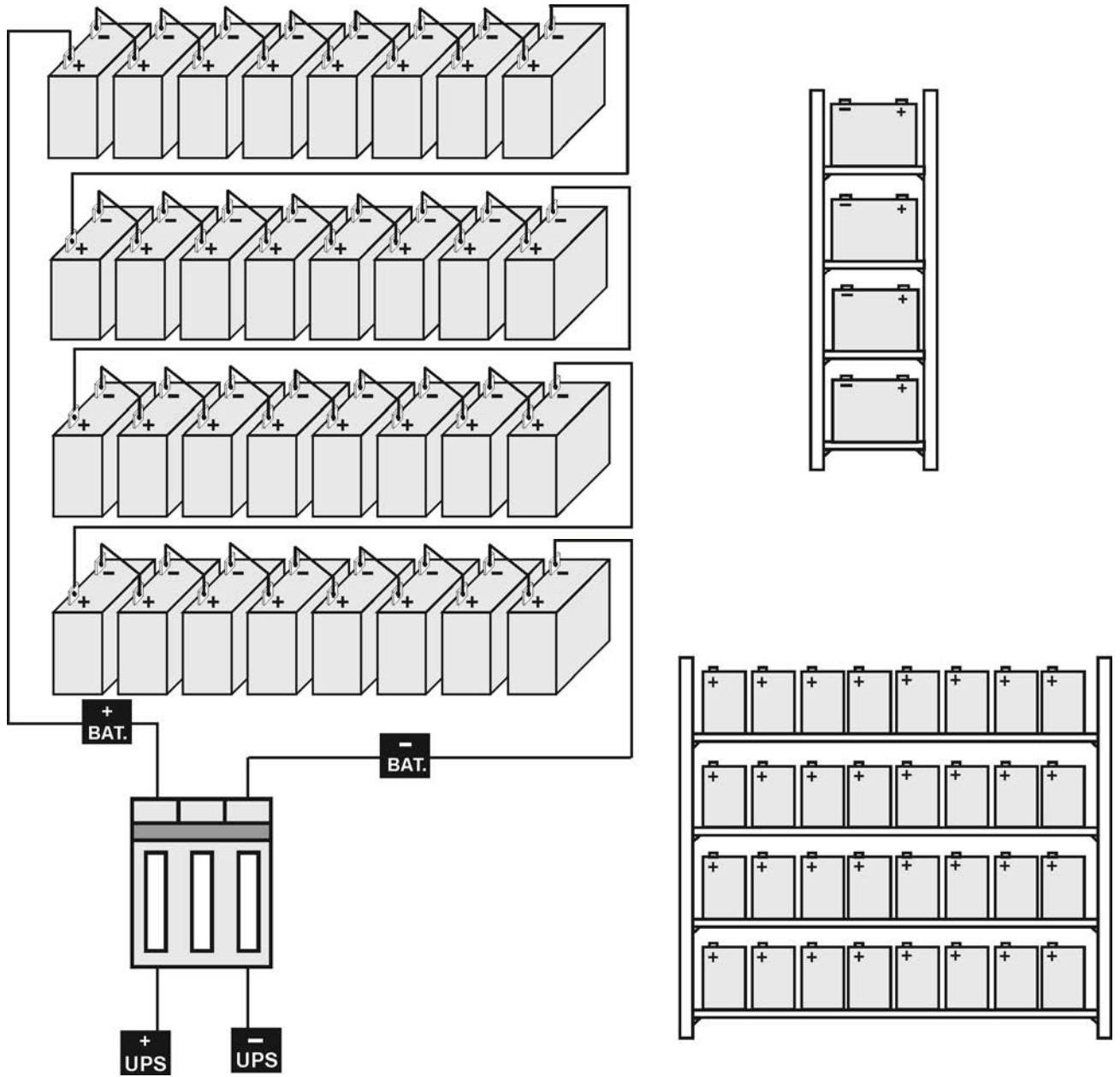

**Figure 5-5** UPS Battery Group Connection

### 5.4.4 The Communication (UPS-Server)

Dry relay alarm contacts or optional RS232 communication port can be used to inform the user about any possible alarm like “Battery Low” “Line Failure” “Load On By-pass”. The relay interface AS400 and Windows NT is a special edition for the systems.

You should use ITF3 and RS330 board for the communicate with the PC. For this connections there must be a dedicated serial port.

**ATTENTION!!!** The communication cables of this option must be shielded and must install away from the voltage cables.

The RS232 port (at RS330 board and DB9 female) definition :

RS232 Signal Gnd (isolated)	7
RS232 Receive	6
RS232 Transmit	9

The settings for the Microsoft NT server®, IBM AS400® connections will be done by the system’s operator in accordance to the each user’s needs.

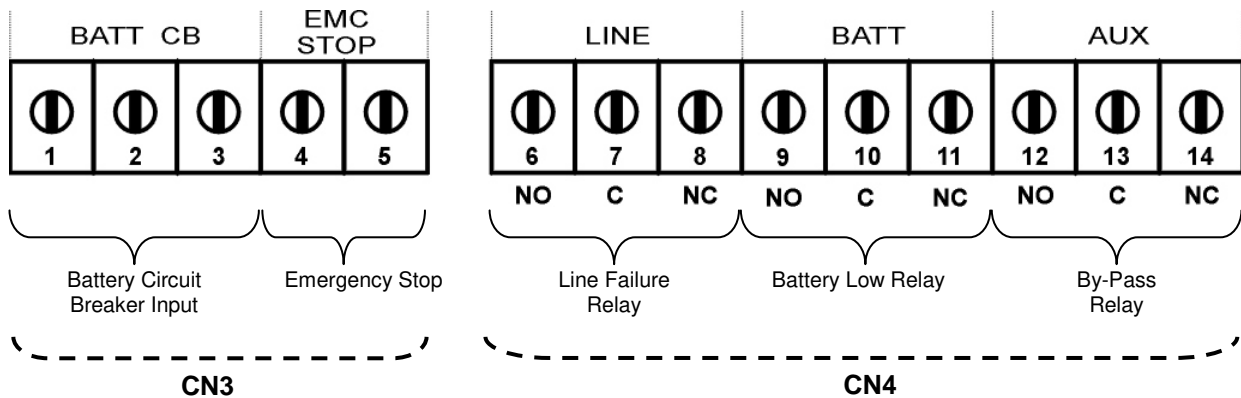

**Figure 5-6** ITF3 Board Connection Details

---

---

## VI . CUSTOMER SERVICE

### **WARNING!**

There are no customer serviceable components inside. DO NOT open the cover or attempt to service the unit. High voltage may remain when the unit is shut down. Unauthorized service will void the warranty and could cause serious injury.

### **6.1 Maintenance**

The unit is designed for easy maintenance. Very little customer maintenance is required. The following will help to ensure trouble -free operation for several years:

1. Vacuum the dust from the ventilation intake on the front panel.
2. Wipe the cover with a damp cloth.
3. Check the batteries charge with the manual battery test procedure. See Automatic And Manual Battery Test.

### **CAUTION!**

It is recommended to test the battery discharging capability only after the software in use has been saved and all files have been closed.

### **6.2 Troubleshooting**

Due to the unique design, the unit can be serviced only by authorized people. In case of a persistent failure or problem properly turn off the unit first. Then review the following check list. Be prepared to answer the questions before calling the service.

1. Did you follow the operation procedure? Did it happen on installation?
2. Did a power failure occur just after or before the malfunction noted on the UPS?
3. What is the indicators status? (see LCD alarms and FAULT codes)
4. Were any changes made recently to unit or the critical equipment connected to the unit?
5. Did an overload condition occur? Remove load from the unit and restart it.
6. Is the utility power phase sequence correct (were any changes phase sequence of the mains)?

### **6.3 Storage**

1. Check the batteries charge with the manual battery test before storage.
2. Connection's uninstall operation will be done by the authorized service.
3. During the storage period the batteries should be charged once, per six months.
4. Keep the equipment and the batteries in a dry, cool place.  
Best storage temperature for the UPS : Between 0°C and 40°C max.  
Best storage temperature for the batteries : Between 10°C and 35°C max.

---

---

## VII. REMOTE MONITORING AND CONTROL

Following external connections are available at T-300P series

- Communication By serial port connection
- Dry contact (interface board) connection
- Remote panel monitoring

### 7.1 Using Serial Port

A standart Serial communication port is installed to all T-300P series UPS, by using this port user can take all information about UPS . All measured parameters, alarms can monitor by this port. This port is interactive and some commands for UPS is available these commands are listed below.

- Switch to BYPASS
- Switch to INVERTER
- SOUND on/off
- Adjust UPS time and date
- Start SIMULATION mode
- Short BATTERY TEST
- BATTERY TEST until battery low alarm
- CANCEL battery test
- Turn off UPS output voltage immediately (SHUTDOWN)
- Turn off UPS output voltage after delay (WAITING SHUTDOWN)
- Turn off UPS output voltage (SHUTDOWN) and turn on UPS output voltage (WAITING RESTART)
- CANCEL SHUTDOWN
- RENAME UPS

UPS will give response to these commands if the **REMOTE: ENABLE** option is selected from **SETTINGS MENU** .

Apply Your local distributor, for supply available programs to monitor and control the UPS.

### 7.2 Serial Communication Cable

The maximum length for RS232 communication cable is 25 meters, cable connector pins are as followed :

UPS side	PC side
9 Tx	2 Rx
7 Gnd	5 Gnd
6 Rx	3 Tx

For remote panel – UPS connection this cable is okay.

### SERIAL PORT SETUP

BAUD RATE	2400 baud
STOP BIT	1
DATABITS	8 BIT
PARITY	None

### 7.3 Modem Connection

A T-300P UPS can be controlled through a normal telephone line by means of a remote operator connected through a PC with modem device, who performs a phone call to the UPS connected number. So the operator can see all parameters and control the UPS (if permitted from SETTINGS MENU).

---

---

### 7.3.1 Hardware Configuration

All needs for modem connection is as follows :

- PC with modem
- WINDOWS 98
- Available UPS control software
- DUMP modem which is connected to UPS

In order to perform this function a PC with UPS control software and an external or internal modem device connected to telephone line are needed.

A standart modem device, configured according to DUMP and auto answer modes, will be installed on the UPS and, once programmed, will following a telephone call of the PC-embedded modem ,connect the UPS to the telephone line.

### 7.3.2 Functioning Principle

The remote operator, by means of a PC and a modem device and using the remote connection function of the control software, calls the UPS through the number to which this is connected.

The dumb modem device, connected to the UPS, will answer the call and convert the data coming from UPS serial on the telephone line. This way all measures and controls allowed by the RS232 serial port can be carried out.

### 7.3.3 SMART Modem Programming (PC modem)

The connected modem to PC (smart modem) will be programmed from UPS control software automaticly.

```
B0 E1 F1 M1 Q0 V1 X3
BAUD = 2400          PARITY = N    WORDLEN = 8
DIAL = TONE
```

```
&A3 &B1 &C1 &D0 &H1 &I0 &K1 &M4
&N0 &R2 &S0 &T5 &Y1
```

### 7.3.4 DUMB Modem Programming

The connected modem to UPS can be program from COMMAND MENU, ENTER: MODEM INIT automaticly. But the user can program this modem from a PC by following options.

```
B0 E1 F1 M1 Q0 V1 X3
BAUD = 2400          PARITY = N    WORDLEN = 8
DIAL = TONE
```

```
&A3 &B1 &C1 &D0 &H1 &I0 &K1 &M4
&N0 &R2 &S0 &T5 &Y1
```

### 7.3.5 DUMB Modem –UPS Connection Cable

The connection cable between dumb modem and UPS is as followed:

UPS DB9 female	MODEM DB25 male
6	3
7	7
9	2

---

---

## 7.4 Dry Contact (Interface) Connection

Some important events can be monitored by this connection for each event a relay is located on interface board and NC-C-NO contacts are connected terminals. these events are:

- LINE FAILURE
- BATTERY LOW
- LOAD ON BYPASS
- BATTERY CB input
- BATTERY CB output
- EMERGENCY STOP input

**ATTENTION:** Max. 42VAC or 60VDC voltage should be applied to the dry contact outputs.

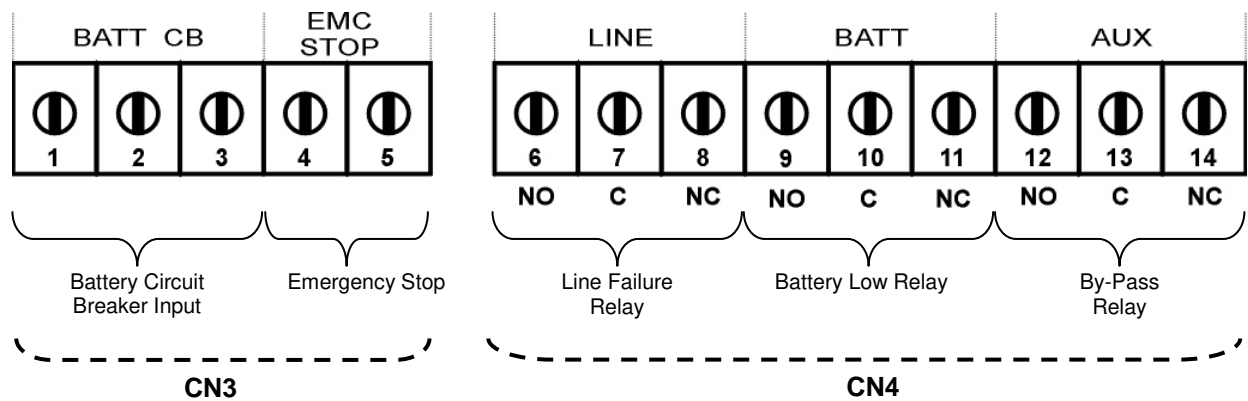

## 7.6 Remote Monitoring Panel

Remote monitoring panel can be used from 400 meters away from UPS. Up to 25 meters there is no need extra hardware RS232 communication is okay. But if distance is longer than 25 meters extra RS485 hardware is needed.

Up to 5 remote monitoring panel can be used in system.

---

---

## VIII. LIMITED WARRANTY

The UPS is warranted against all defects in workmanship and materials under normal use for a period of one ( ) year from the date of shipment to the original user. The conditions of this warranty and the extent of responsibility of

.....

corporation under this warranty are as follows.

1. The warranty does not apply if the product has been subjected to physical abuse, improper installation, unauthorized service or modification.

2. The sole responsibility of

.....

corporation under this warranty shall be limited to the repair or replacement of the product, at the sole discretion of

.....

corporation.

3. If it becomes necessary to send a defecting unit to

.....

corporation, the product should be shipped in its original carton or in suitable equivalent, and with shipping charges prepaid.

.....

corporation will not assume any responsibility for any loss damage incurred in shipping.





AGKK6221 02/2010